

Purigo T

Air filtration



KEY FEATURES

- Indoor air purification for both commercial and domestic residential applications.
- EPM10 and EPM1 filters with effectiveness of 80% and 70% combined with HEPA 14 filtration.
- Low maintenance product with minimal user interaction and filter change indicators for easy maintenance.
- Easy user control system, simple plug in and go with stepless regulation and low noise operation.
- Significantly reduces virus load through 2 stage cleaning process and effective room air changes.
- Compatible with all MVHR and mechanical ventilation systems and effective for non-ventilated spaces.

PURIGO T

The Purigo range consists of the Purigo M850, Purigo T 1750 and Purigo T 2200. Airflow developments presents the T model as its most powerful air purifier product. The 2200 can offer 611 l/s of air filtration and the 1750 can offer 486 l/s. These airflow rates can provide protection for classrooms, offices, restaurants, factories, gathering places, shops and any other space against virus transmission.

The product draws in indoor air and puts it through a 2-stage cleaning process. First through its EPM filters which can filter small particles sizes 0.3 to 10.0 μm and then through

HEPA 14 filters, commonly used in hospital wards to capture 99% of particles size 0.3-1 μm . This is guaranteed to remove harmful particles which would otherwise be inhaled.

The products are easy to maintain, have filter change indications when they need to be replaced, run at very low noise levels, and can be used to protect occupants and unventilated spaces, such as in a retrofit project.



TECHNICAL SPECIFICATION

Specification	T1750	T2200
Airflow Volume min (m ³ /h)	300	370
Airflow Volume max (m ³ /h)	1750	2200
Max covering area (m ²)*	146	183
L _w A (min) (dBa)	30	31
L _w A(max)(dBa)	65	68
L _p A(min) @1m (dBa)	22	23
L _p A(max) @1m (dBa)	57	60
Power Max (W)	494	473
Voltage (V)	230	230
Amps (A)	2.5	2.5
Frequency (Hz)	50	50
Height (mm)	2313	2332
Width (mm)	717	717
Depth (mm)	567	720
Weight (Kg)	150	185
Protection IP Rating	20	20
Body Construction	Standing Tower	Standing Tower
Silencers	2	2
Filter 1	ePM10 70%	ePM10 70%
Filter 2	ePM1 80%	ePM1 80%
Filter 3	HEPA14	HEPA14
Colour of body	White	White
Product Number	90001461	90001462

*with 4 air changes per hour and 3m room height



DIMENSIONS

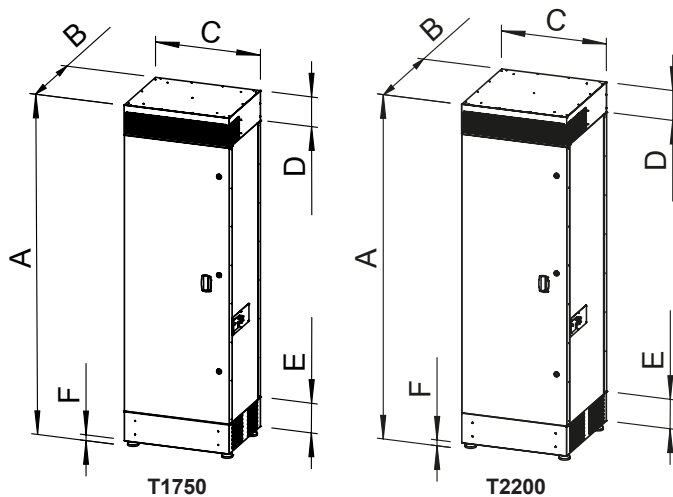

Model	A	B	C	D	E	F
T1750	2313	565	717	203	200	39
T2200	2332	719	717	203	200	39

SETTING DATA

T1750				T2200			
Adjustment levels	Air Volumes (m ³ /h)	Noise level at 1m(dBa)	Power (W)	Adjustment levels	Air Volumes (m ³ /h)	Noise level at 1m (dBa)	Power (W)
20	0-300	22	11	20	0-370	23	18
25	300-370	27	14	25	370-460	28	21
30	370-480	33	21	30	460-570	33	25
35	480-565	35	29	35	570-700	38	32
40	565-660	39	42	40	700-810	40	39
45	660-740	41	52	45	810-915	42	49
50	740-850	44	71	50	915-1050	44	63
55	950-935	46	90	55	1050-1160	45	79
60	935-1025	49	113	60	1160-1265	45	99
65	1025-1110	51	141	65	1265-1400	46	128
70	1110-1220	53	180	70	1400-1505	46	158
75	1220-1305	54	217	75	1505-1615	47	194
80	1305-1400	56	261	80	1615-1750	49	244
85	1400-1480	57	310	85	1750-1850	51	294
90	1480-1590	57	376	90	1850-1960	54	351
95	1590-1680	57	439	95	1960-2075	57	415
100	1680-1750	57	494	100	2075-2200	60	473



Purigo M

Air filtration

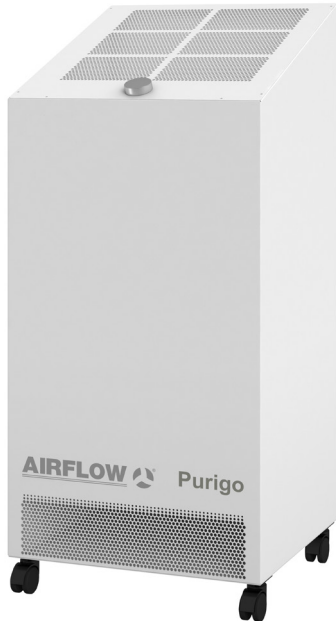

KEY FEATURES

- Mobile Indoor air purification for both commercial and domestic residential applications.
- EPM1 filters with effectiveness of 70% combined with HEPA 14 filtration.
- Low maintenance product with minimal user interaction and filter change indicators for easy maintenance.
- Easy user control system, simple plug in and go with stepless regulation and low noise operation.
- Significantly reduces virus load through 2 stage cleaning process and effective room air changes.
- Compatible with all MVHR and mechanical ventilation systems and effective for non-ventilated spaces.

PURIGO M

The Purigo range consists of the Purigo M650, Purigo T 1750 and Purigo T 2200. Airflow developments presents the M model as its most powerful mobile air purifier product. The M850 can offer 236 l/s of air filtration. These airflow rates can provide protection for classrooms, offices, restaurants, factories, gathering places, shops and any other space from virus transmission.

The product draws in air and puts it through a 2-stage cleaning process. First through its EPM filter which can filter small particles sizes 0.3 to 1 μm and then through a HEPA

14 filter commonly used in hospital wards to capture 99% of particles size 0.3-1 μm .

This is guaranteed to remove harmful particles which would otherwise be inhaled. The products are easy to maintain, have filter change warnings when they need to be replaced and run at very low noise levels. They can be used to protect occupants and unventilated spaces, such as in a retrofit project.



TECHNICAL DATA

Specification	M850
Airflow Volume min (m ³ /h)	150
Airflow Volume max (m ³ /h)	850
Max covering area (m ²)*	71
L _w A (min) (dBa)	34
L _w A (max) (dBa)	66
L _p A (min) @1m (dBa)	26
L _p A (max) @1m (dBa)	58
Power Max(W)	168
Voltage (V)	230
Current (A)	1.7
Frequency (Hz)	50
Height	1139
Width	515
Depth	461
Weight (Kg)	40
Protection IP Rating	20
Body Construction	Mobile
Filter 1	ePM10 70%
Filter 2	HEPA14
Control	Stepless
Colour of body	White
Product Number	90001460

*with 4 air changes per hour and 3m room height



DIMENSIONS

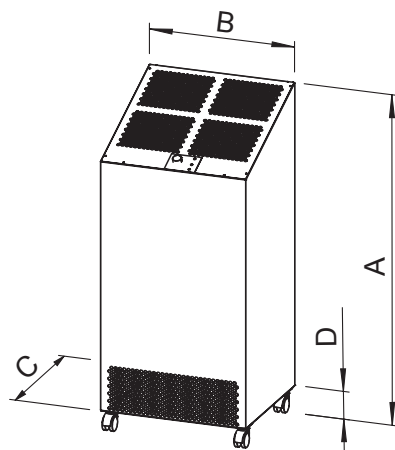

M850

Model	A	B	C	D
M850	1139	515	460	72

SETTING DATA

M850			
Adjustment levels	Air Volumes (m ³ /h)	Noise level at 1m(dBa)	Power (W)
20	0 - 140	26	4
25	140 - 200	30	6
30	200 - 250	32	9
35	250 - 315	36	13
40	315 - 365	39	18
45	365 - 420	42	24
50	420 - 490	45	36
55	490 - 530	47	45
60	530 - 590	50	60
65	590 - 650	52	78
70	650 - 700	54	97
75	700 - 768	56	125
80	768 - 815	57	149
85	815 - 830	57	160
90	830 - 844	58	168
95	844 - 844	58	168
100	844 - 844	58	168

Call: 01494 525252

Visit: airflow.com



Airflow Developments Limited
Aidelle House, Lancaster Road,
Cressex Business Park,
High Wycombe, Buckinghamshire,
United Kingdom, HP12 3QP

E-mail: info@airflow.com
Telephone: +44 (0) 1494 525252

airflow.com

© Airflow Developments Limited. Airflow Developments Limited reserve the right, in the interests of continuous development, to alter specifications without prior notice. All orders are accepted subject to our conditions of sale which are available on request

80001125 - Issue 1 11/21

